

Appendix A: Firmware structure diagrams

SPEED REFERENCE CHAIN

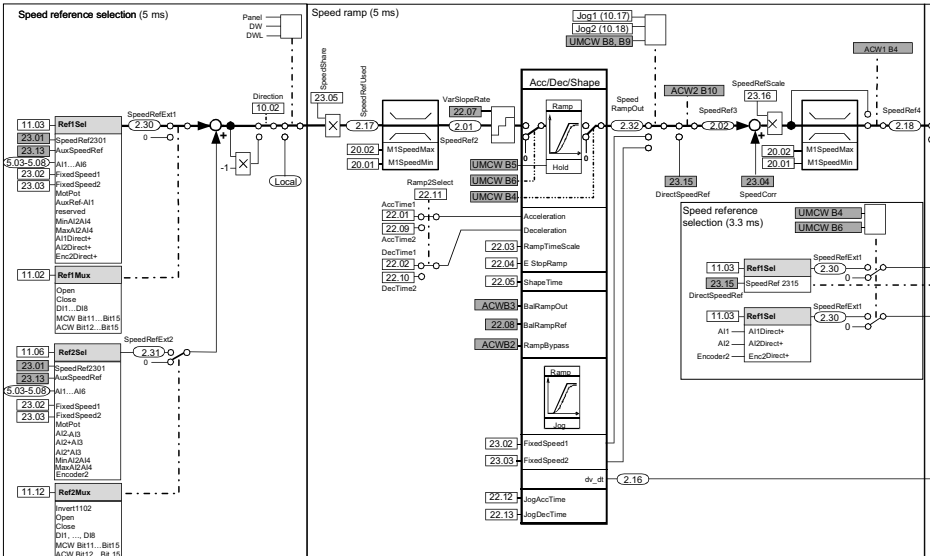

SPEED CONTROL

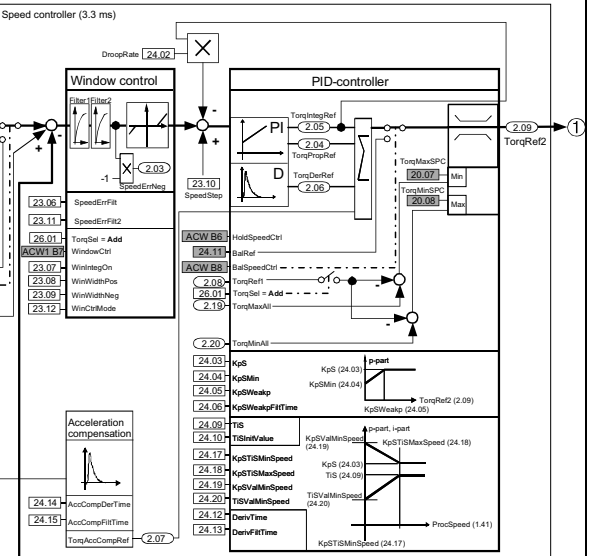

SPEED ACTUAL CHAIN

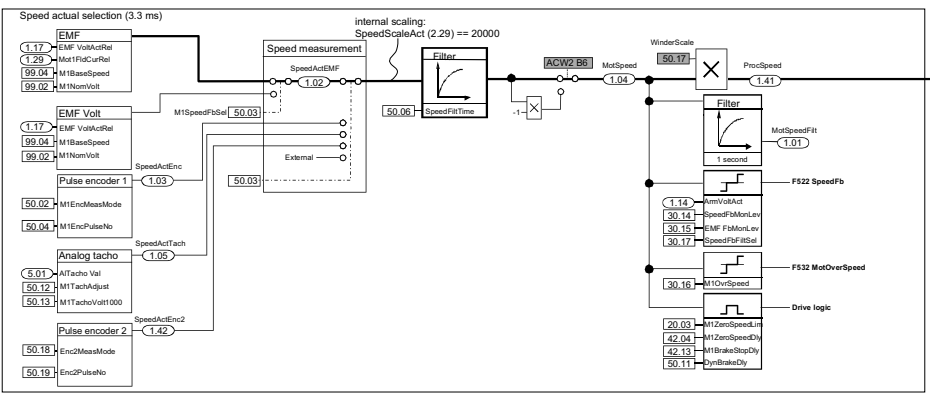

Legend

- Signal
- Parameter
- Parameter is usually written to by Adaptive Program, application program or overriding control

Attention:
The firmware structure diagrams show the **standard** firmware

D8CS00_Fw_structure_diagram_rev_i.dsf

TORQUE CONTROL CHAIN

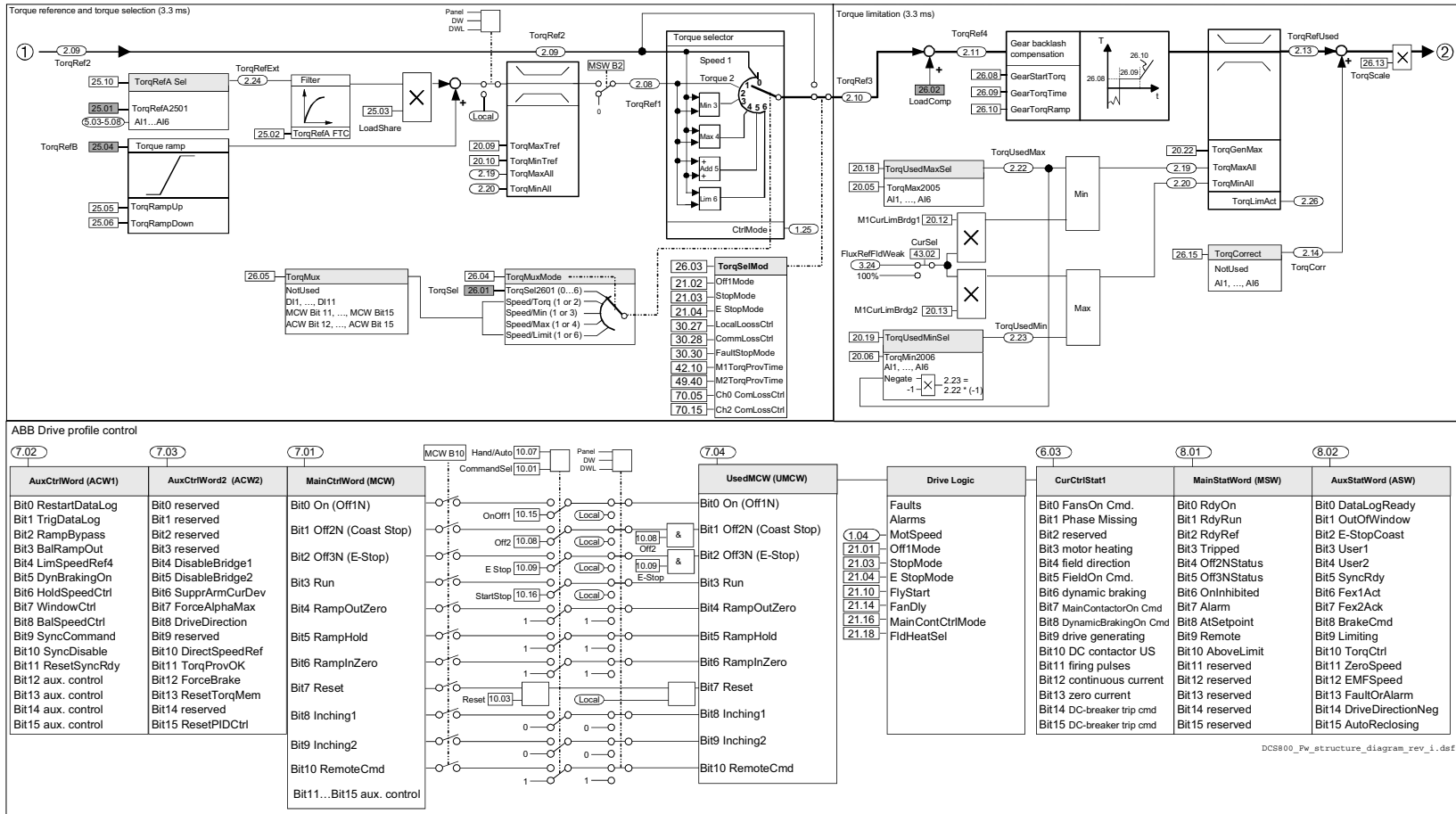

DCS800_Fw_structure_diagram_rev_i.dsf

ARMATURE CURRENT CONTROL

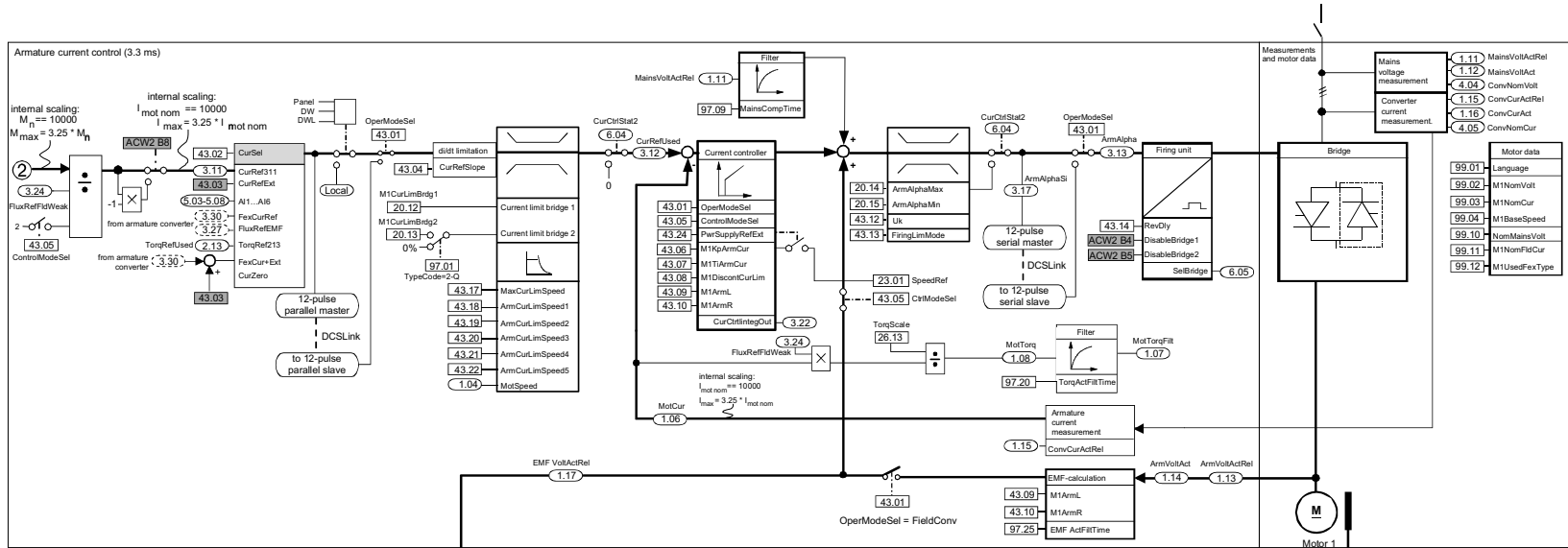

FIELD CURRENT CONTROL (one field exciter)

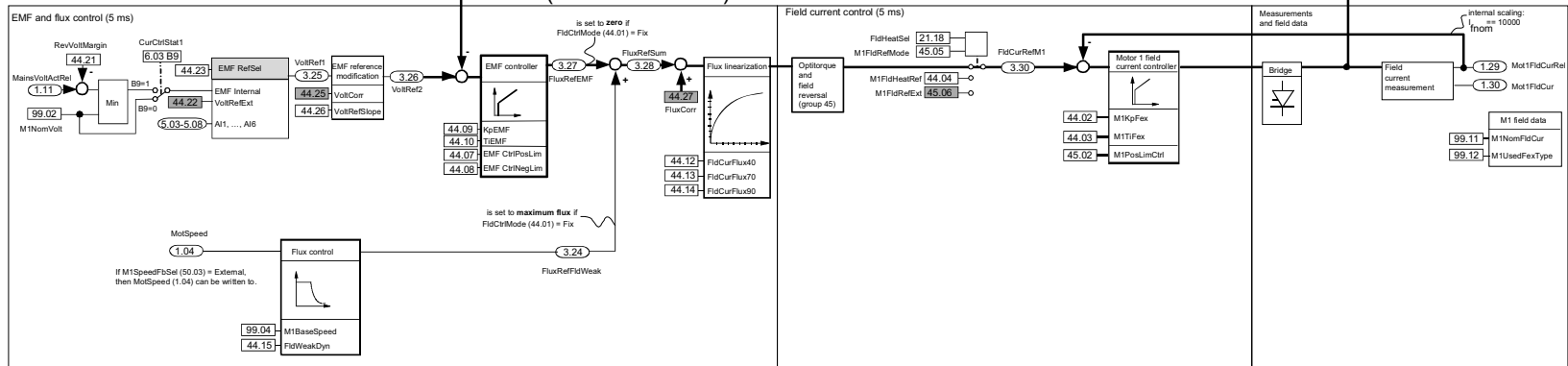

DCS800_Fw_structure_diagram_rev_1.dxf

ARMATURE CURRENT CONTROL

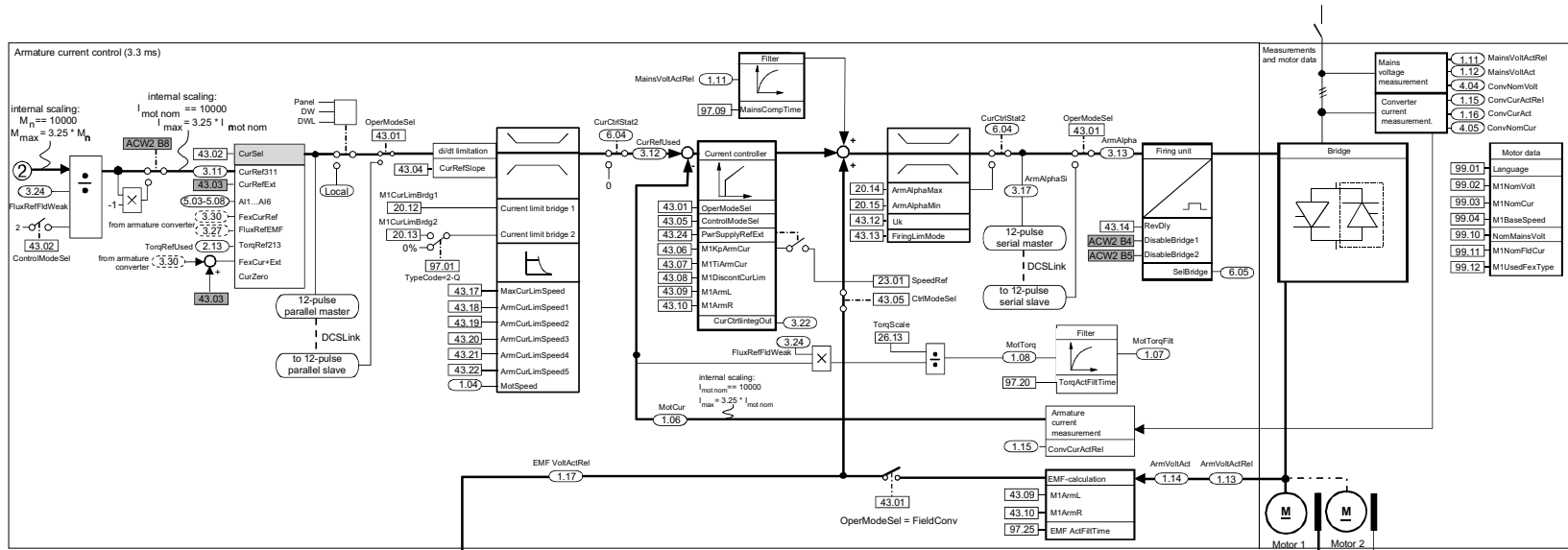

FIELD CURRENT CONTROL (two field exciters)

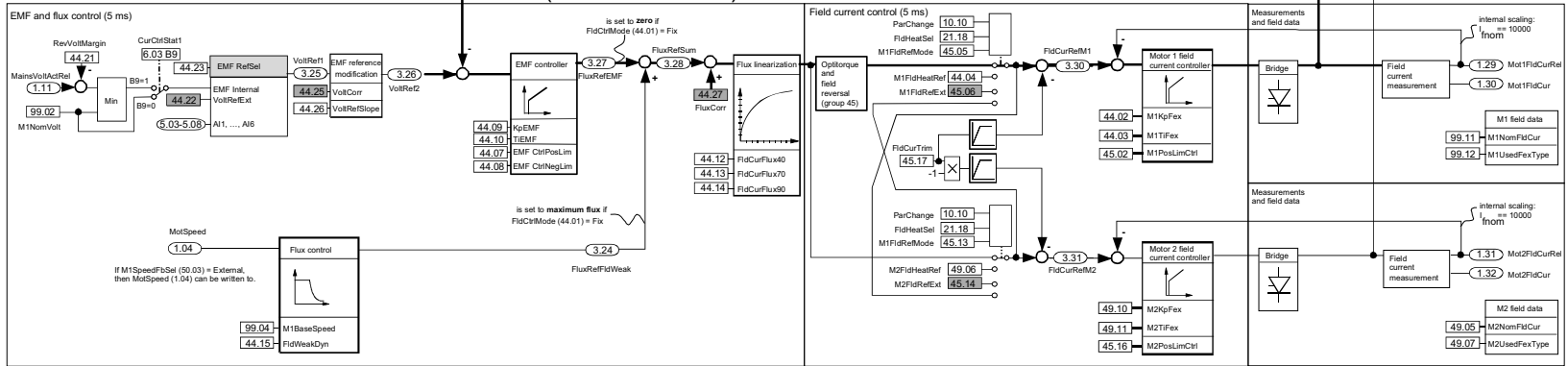

DCS800_Pw_structure_diagram_rev_1.dxf

ADDITIONAL FUNCTIONS

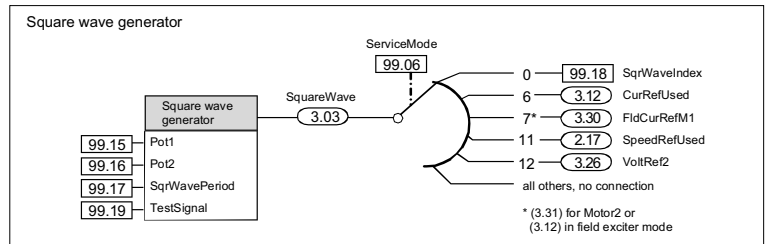
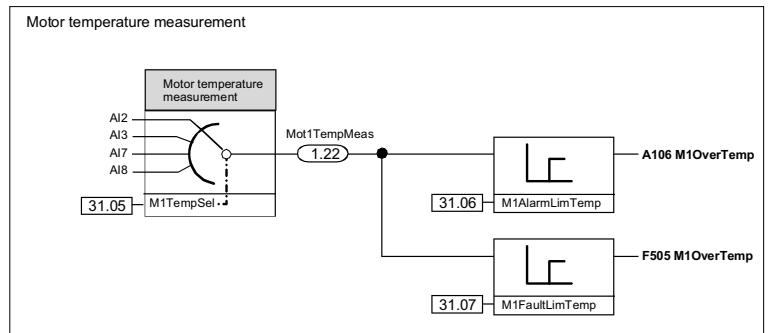

DCS800_Fw_structure_diagram_rev_i.dsF